



NDOLA TRUST SCHOOL

(Ndola Trust School Limited)

"Success through Hard Work"

www.ndolatrustschool.edu.zm

WEEK 9



MATHEMATICS

Symmetry

A line of symmetry divides an object or shape into two halves which are exactly the same. Observe in the environment things which could have a line of symmetry.

Examples

Letters: A B C H

Numbers: 3 8

Shapes:

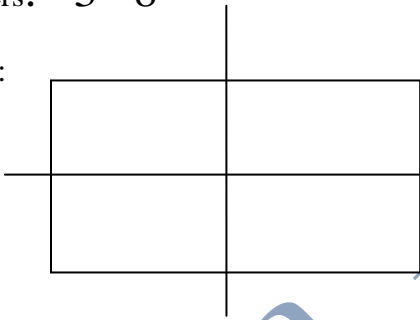

A rectangle has 2 lines of symmetry

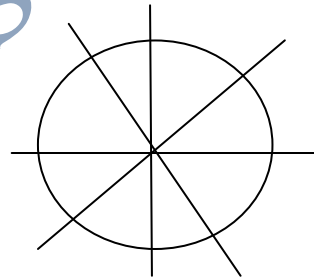

A circle has many lines of symmetry

Activity

Draw lines of symmetry in the following shapes.

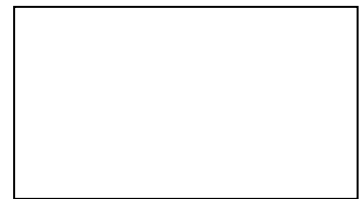
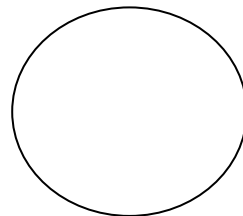
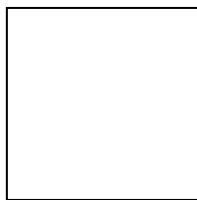
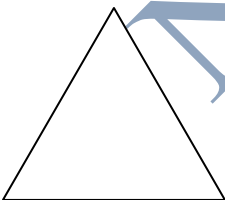

PHONICS

Suffix

Suffix – put after a word.

Examples

Use + full = usefull

Harm + less = harmless

Activity

Copy and complete

Care + full =

Hope + full =

Joy + full =

Rest + full =

Thought + full =

Hand + full =

SPELLING WORDS

- | | |
|----------------|--------------|
| 1. church | 9. carefull |
| 2. leader | 10. useless |
| 3. fuel | 11. Power |
| 4. torch | 12. moon |
| 5. light | 13. sun |
| 6. electricity | 14. uniform |
| 7. torn | 15. harmless |
| 8. dress | |

Activity

Write 5 words sentences using spelling words.

MATHEMATICS

Symmetry

Activity

Draw lines of symmetry in the following letters.

M E W B

RELIGIOUS EDUCATION

Church leaders

List church leaders and ministers.

church leaders

pastors
priest
reverend
elders
ministers

ministers

church minister
catechists
choir leaders
readers
alter
Saturday or Sunday school teachers

Church person

Pastors, priest, reverend
Choir
Altar servers
Women's league

Dress or uniform

vestment's or cassock
uniforms – red jackets
Alb or cassock or surplice red or black
blue or red, black or red chitenge

Activity

Draw your church leaders.

ORAL LANGUAGES

Use of has and have

For one person or thing we use has.

For more than one person or more we use have.

Always use have with I or you.

Examples

Our cat has kittens.

The children have gone to the circus.

Activity

Write has or have in each space.

1. Simon _____ lost his dinner money.
2. Where _____ you been all day?
3. The books _____ been left out.
4. _____ Dad come home yet?
5. The book _____ been lefts out.
6. _____ the children come home yet?
7. _____ the postman called?
8. The elephants _____ a long trunk.
9. Elephants _____ long trunks.
10. Both the kittens _____ grey fur.

MENTAL MATHS

1. How many legs have 20 boys?
2. How many twos are there in 30?
3. A teacher has 30 books. He gives 6 books to every pupil. How many pupils were there?
4. They are 28 girls and every girl has 2 pencils. How many pencils are there?
5. 22, 24, 26, _____, _____.

GRAMMAR

Conjunctions

Using and

We can join these two sentences below by using and. And is a conjunction.

Simon is going fishing.

I am going fishing.

Answer Simon and I are going fishing.

John is tall.

John is strong.

Answer John is tall and strong.

Activity

Use and to join each pair of sentences below.

1. Our cat is white.
Our cat is fluffy.
2. The room was clean.
The room was tidy.
3. Grandpa sat in the armchair.
He fell fast asleep.
4. The day was fine.
The day was warm.
5. I gave the newsagent K50.
I had K5 change.

SCIENCE

WEATHERING

What is weathering?

Weathering is formed when rocks break up into smaller pieces to form soil.

Causes of weathering

1. Animals : Animals breaks up rocks when they walk over them.
2. People : People break up rocks when building houses, farming, building roads and walking over them.
3. Wind : when the wind blows, the rocks wears off.
4. Temperature : Expansion and contraction of rocks.

5. Plants : Plants often grow in the cracks of the rocks.

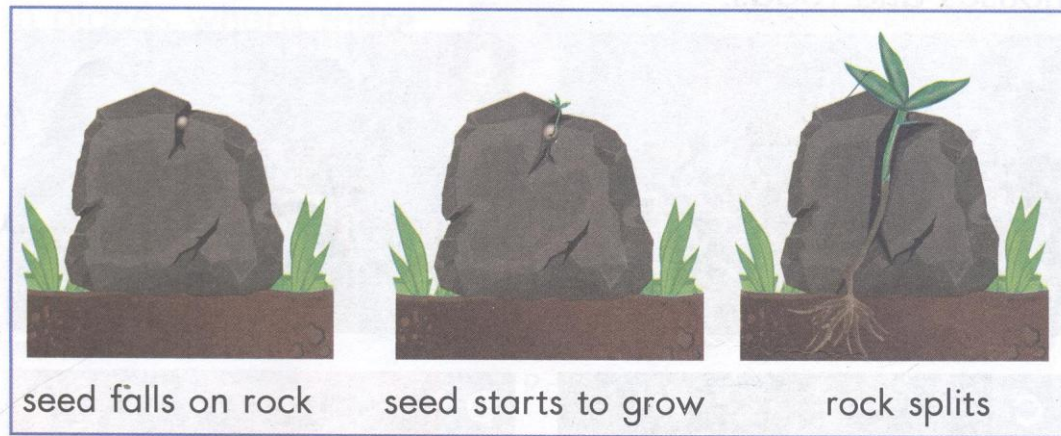

Weathering of rock caused by plants

6. Water: when it rains water falls on the rocks and the rocks splits.

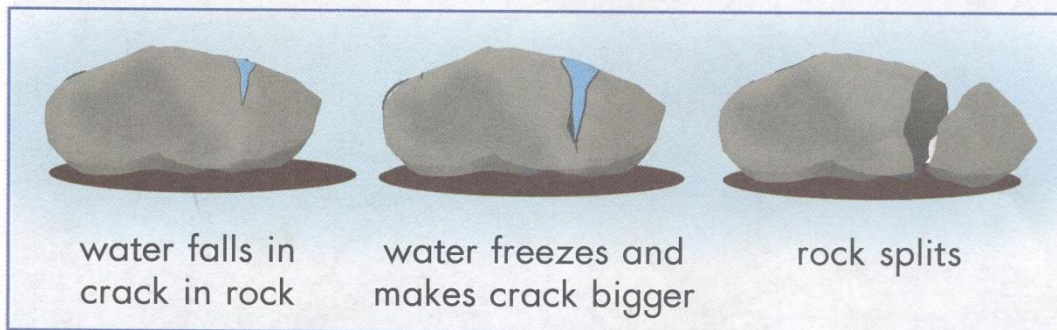

Weathering of rock caused by water

Activity

1. Draw 3 pictures to show how plants can weather rocks. Label your pictures.
2. Complete the sentences below. Write the sentences under your pictures.

Plants can _____ rocks. The plants grow in the _____ of rocks. When the roots of the plants get bigger, the rock _____.

CREATIVE WRITING

Pretend that you and your friend have a ball. Describe a game in which you could all join.

Below are words to help you write a story.

football	play	netball	kick
cricket	hiding	tennis	outdoor
throw	skipping		

CREATIVE AND TECHNOLOGY STUDIES

Energy – main parts of a torch.

A torch gives us light. It helps us see in the dark. Many people use torches.

Natural light

1. Moon
2. Stars
3. Sun

Artificial light

1. candle
2. lamp
3. torch
4. bulb

Activity

1. Label the torch using the following names:
glass, spring, main cover, switch, bulb.

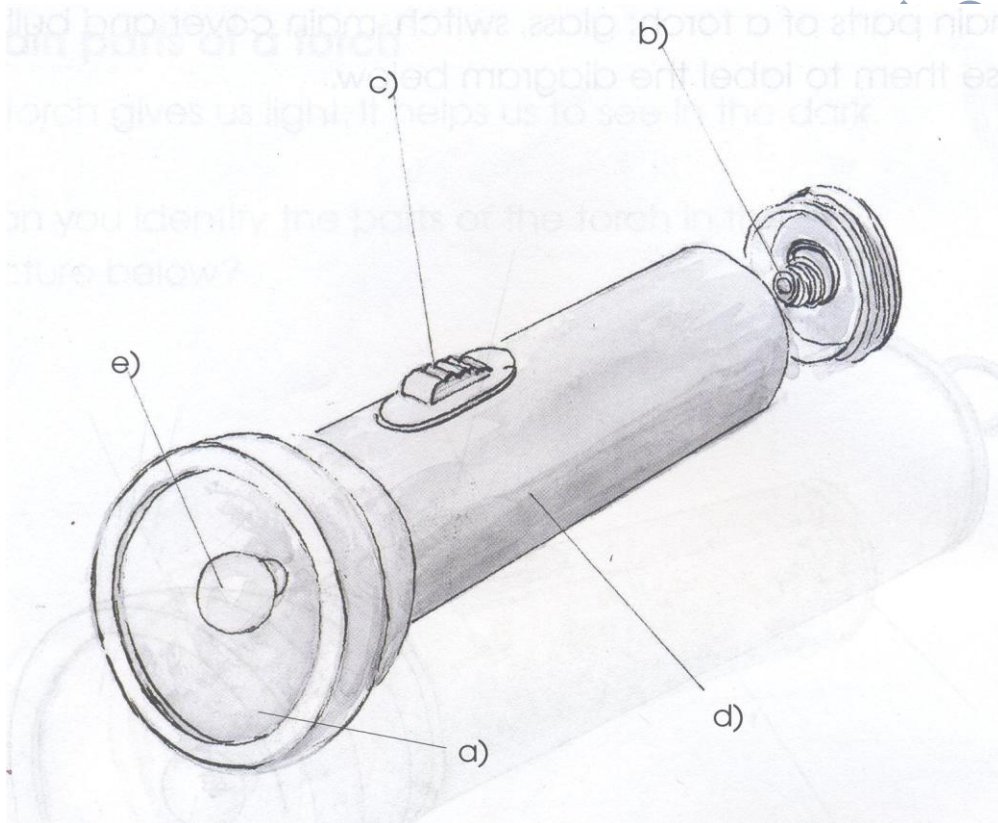

PHONICS WORKSHEET

Sound "or"

Use or to make words.

1. c_____n
2. b_____n
3. t_____n
4. th_____n
5. h_____n
6. m_____ning
7. w_____n
8. n_____th
9. st_____ry
10. sp_____t

SOCIAL STUDIES

Fuel – is something that can burn or produce heat or power.

Examples of fuel

1. kerosene – obtained from crude oil.
2. Diesel – obtained from crude oil.
3. Petrol – obtained from crude oil.
4. Gas – comes from underground.
5. Coal – comes from underground.
6. Charcoal and wood – obtained from trees.
7. Dung – obtained from animal waste.

Activity

Children to write different fuels used in homes.

ART WORK

Draw natural light and colour them.