



NDOLA TRUST SCHOOL

(Ndola Trust School Limited)

"Success through Hard Work"

www.ndolatrustschool.edu.zm

WEEK 7 WORK



MATHEMATICS

PERIMETER

What is perimeter? Perimeter is the total distance around a given shape. To find the perimeter, we add the distance around that shape.

Example

Find the perimeter.

1.

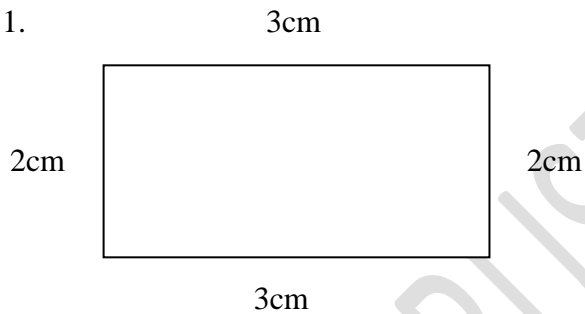

$$P = 3\text{cm} + 3\text{cm} + 2\text{cm} + 2\text{cm}$$

$$P = 10\text{cm}$$

2.

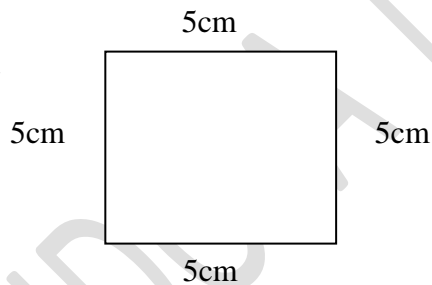

$$P = 5\text{cm} + 5\text{cm} + 5\text{cm} + 5\text{cm}$$

$$P = 20\text{cm}$$

Activity

Find the perimeter.

1.

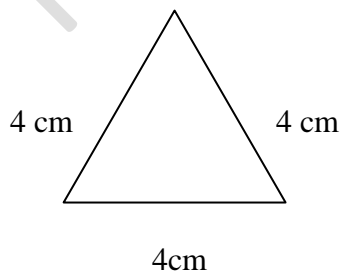

5.

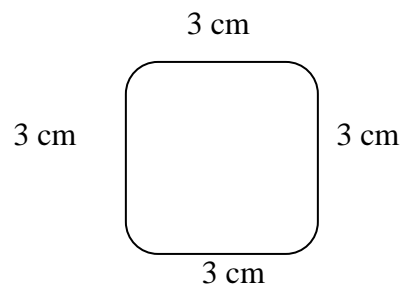

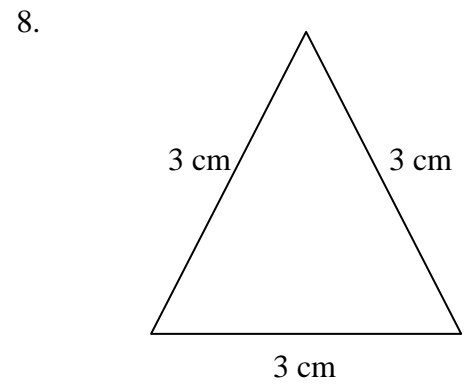
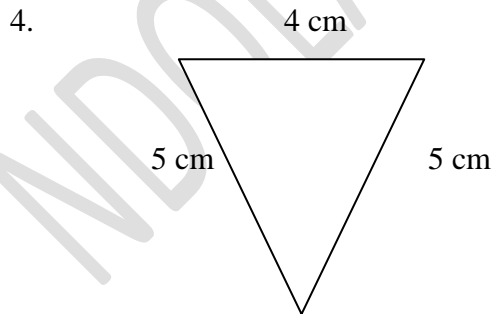
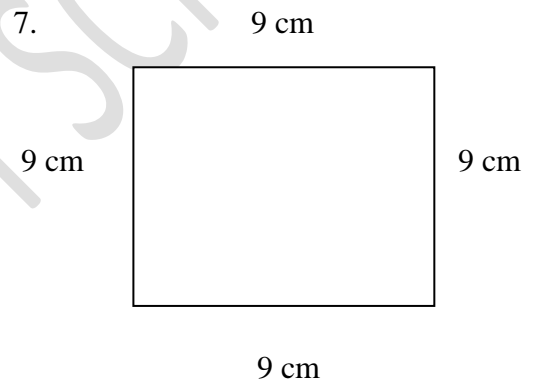
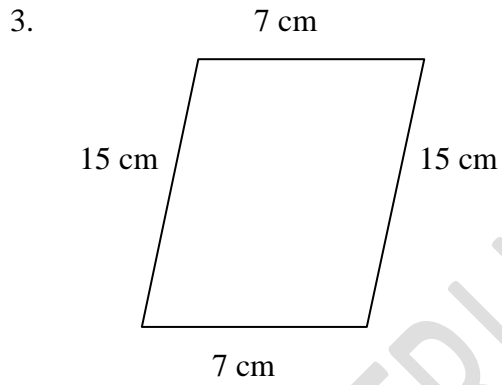
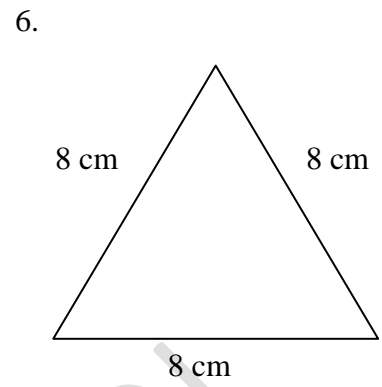
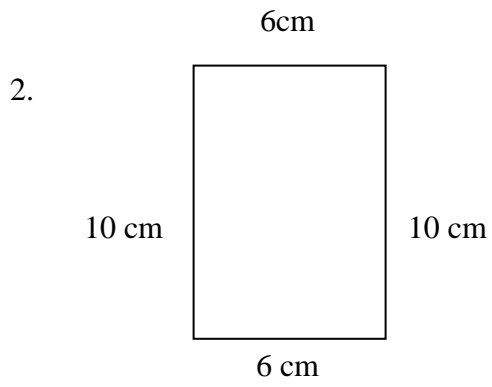

PHONICS

Sound “ear”

Examples

Add **ear** to make words.

1. Sp _____ - spear

2. Cl _____ - clear

Activity

Add ear to make words.

1. h _____

2. d _____

3. y _____

4. disapp _____

5. t _____ s

6. f _____

7. d _____ ly

8. app _____

9. r _____

10. reap _____

11. sh _____ ring

12. sm _____

SPELLING WORDS

1. year

2. tear

3. concert

4. letter

5. bird

6. skirt

7. driver

8. danger

9. carrots

10. food

11. Drum

12. Camel

13. Canoe

14. Snake

15. Meal

Activity

Write 5 sentences using spelling words.

RELIGIOUS EDUCATION

The Bus Driver

List the qualities of a good driver.

- Doesn't drive fast.
- Watches out for danger.
- Repairs his vehicles.
- Starts off on time.
- Is polite to passengers.
- Keeps the rules of the road.

Activity

List 5 qualities of a bad driver.

- a.
- b.
- c.
- d.
- e.

ORAL LANGUAGE

The Question Mark.

A sentence which asks something is called a **question**. When a question is written, there must be a question mark at the end instead of a full stop. It is made like this ?

Words to use when asking questions:

Who what when why

Which how whose where

Activity

Use these words to fill in the blank spaces.

- a. _____ colour is the shell?
- b. _____ are you going to, my pretty maid?

- c. _____ is your favorite flower?
d. _____ will come to the park with me?

Remember to use a capital letter when starting a sentence.

MATHEMATICS

Perimeter

Activity

1. Find the perimeter of the shapes below

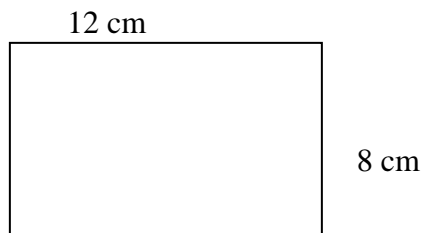

- 2.

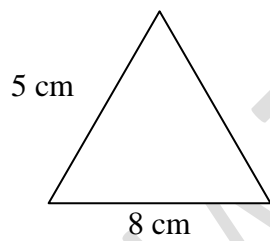

- 3.

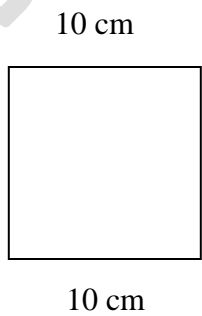

GRAMMAR

The not words

We sometimes join not to another word. When we do this we leave out o in not and write ' in its place.

Examples

Is not – isn't

Has not – hasn't

Are not – aren't

Does not – doesn't

Was not – wasn't

Were not – weren't

Activity

Join each pair of words together.

1. Does not -
2. Were not -
3. Is not -
4. Has not -
5. Would not -
6. Was not -
7. Do not -
8. Have not -
9. Could not -
10. Did not -

MATHS TABLES

Revise the tables of 3 and 4.

1. $3 \times 3 =$
2. $3 \times 8 =$
3. How many legs have 4 tables?
4. How many sets of fours are there in 24?
5. How many threes are there in 30?

SCIENCE

FOOD CHAIN

Food chain is the order in which animals eat plants and other animals.

Examples

- a. Grass → grasshopper → frog → snake → hawk
- b. Maize corn → rat → owl
- c. Carrot → rabbit → fox → lion
- d. grass → butterfly → frog → snake

Activity

Copy and complete

- 1. grass → → →
- 2. carrots → → →
- 3. cow →
- 4. Plants → → lion

CREATIVE WRITING

Write about the work which has to be done in the garden. If you have a garden at home, describe it and say exactly what you do in it.

Words to help you write a story.

- | | | | | |
|--------|------------|------|----------|-------|
| Soil | rain | dew | hose | grow |
| Weed | vegetables | lawn | spade | hoe |
| Border | earth | path | trim | plant |
| Rake | flowers | sow | watering | grass |

PHONICS

Sound er and ir

ir

birth
bird
chirp
dirt
girl
shirt
confirm
circus
twirl
third
skirt

er

after
copper
fern
finger
letter
otter
member
scatter
number
hammer
another

Activity

Use ir or er to make words

Ir

f _____ m
d _____ t
b _____ d
f _____ st
g _____ l

er

farm _____
sum _____
rul _____
zipp _____
hamm _____

CREATIVE AND TECHNOLOGY STUDIES

We can eat food in the morning, afternoon or evening. A small meal that is eaten between main meals is called a snack.

1. The first meal of the day is called Breakfast.
2. The meal you eat in the middle of the day is called lunch.
3. The meal you eat at the end of the day is called Dinner.

Activity

Write the food you can eat at:

a. Breakfast (morning)

- 1.
- 2.
- 3.
- 4.

b. Lunch (mid – day)

- 1.
- 2.
- 3.
- 4.
- 5.

c. Dinner (evening)

- 1.
- 2.
- 3.
- 4.
- 5.

SOCIAL STUDIES

Ancient Transport

Examples

1. Animals
 - Ox- cart
 - Dogs
 - Horses
 - Camels
 - Donkey
2. Walking
3. Canoes
4. Rafts

Ancient Communication

Examples

1. drums
2. smoke
3. fire
4. runners
5. bell

Advantages of ancient Transport and Communication

1. It was cheap, drums were made from animal skin.
2. It was clean to the environment.
3. It did not pollute the environment.
4. It was easy to maintain.
5. It uses resources available in the community.

Activity

Draw three ancient transport and three ancient communication.