



NDOLA TRUST SCHOOL

(Ndola Trust School Limited)

"Success through Hard Work"

www.ndolatrustschool.edu.zm



REVISION WORK FOR WEEK 11

MATHEMATICS

Division

1. $12 \div 3 =$

2. $15 \div 5 =$

3. $16 \div 2 =$

4. $20 \div 4 =$

5. $\underline{\quad} \overline{) 2 \ 10}$

7. $\underline{\quad} \overline{) 3 \ 15}$

6. $\underline{\quad} \overline{) 3 \ 9}$

8. $\underline{\quad} \overline{) 2 \ 8}$

Long division

1. $\underline{\quad} \overline{) 2 \ 34}$

$\underline{\quad} \overline{) 2 \ 86}$

$\underline{\quad} \overline{) 2 \ 92}$

2. $\underline{\quad} \overline{) 3 \ 46}$

4. $\underline{\quad} \overline{) 2 \ 150}$

Addition

1. Th H T O

$$\begin{array}{r} 1\ 4\ 2\ 6 \\ +\ 3\ 5\ 3 \\ \hline \end{array}$$

2. Th H T O

$$\begin{array}{r} 1\ 1\ 2\ 4 \\ +\ 7\ 3\ 2\ 1 \\ \hline \end{array}$$

3. Th H T O

$$\begin{array}{r} 6\ 2\ 4\ 2 \\ +\ 3\ 4\ 3\ 1 \\ \hline \end{array}$$

4. Th H T O

$$\begin{array}{r} 1\ 8\ 5\ 3 \\ -\ 9\ 8\ 7 \\ \hline \end{array}$$

5. Th H T O

$$\begin{array}{r} 2\ 6\ 8\ 7 \\ -\ 3\ 1\ 5\ 5 \\ \hline \end{array}$$

6. Th H T O

$$\begin{array}{r} 1\ 5\ 8\ 3 \\ -\ 1\ 8\ 9\ 7 \\ \hline \end{array}$$

Perimeter

Find the perimeter.

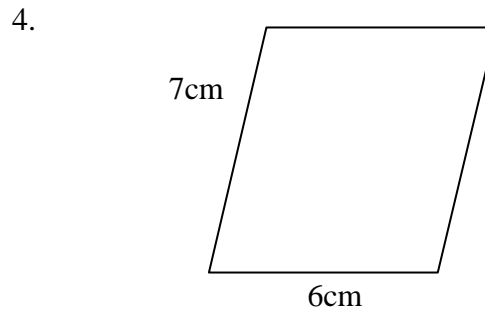
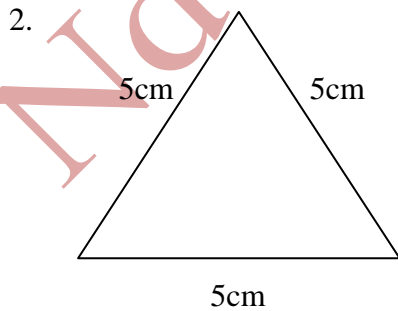
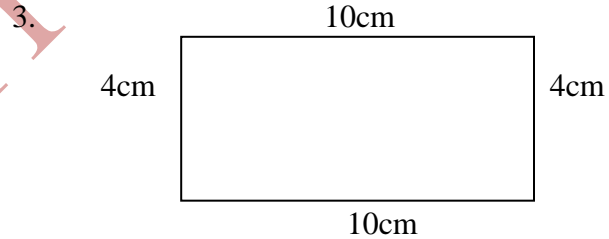
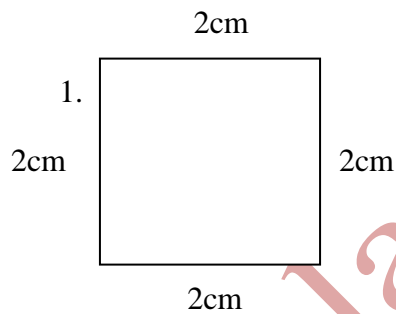

Number Patterns

- 1, 3, 9, _____, _____.
- 10, 20, 30, _____, _____.
- 400, 300, 200 _____.
- 50, 100, 150, _____.
- 240, 120, 60, _____.

Brackets

- $(4 \times 3) + 5 =$
- $(24 \times 2) - 3 =$
- $(24 - 10) + 2 =$
- $(17 + 3) - 5 =$

GRAMMAR

Exercise A : write in plural form

1. Hen –
2. Cow –
3. Duck –
4. Horse –
5. Church-
6. Shelf –
7. Pony –
8. Leaf -
6. Torch -
7. Box -
8. Brush -
9. Bus -
10. Lady –

Exercise B:

Animals **babies** **home** **sound**

Cat

Cattle

Duck

Dog

Hen

Lion

Exercise C

Homophones:

1. I love the _____ of popped popcorn.
sent scent
2. Can you _____ the door to your bedroom.
close clothes
3. My parents are going on a boat _____.
crews cruise
4. I got some new _____ when we went shopping.
close clothes
5. The new _____ has been picked for a new school.
sight site
6. Which puppy did you _____? The black or brown one.
chews choose
7. What kind of _____ do you like for breakfast?
cereal serial
8. He _____ his gum so loudly.
choose chews

Exercise D

Opposites

1. Empty –
2. Young –
3. Inside –
4. Rough –
5. Rich –
6. Top –
7. Closed –
8. Hot –
9. Happy –
10. Paid
11. Tidy –
12. Kind –
13. Well –
14. Pack –
15. Do –

- 16. Wind –
- 17. Screw –
- 18. Wrap –
- 19. Tie –
- 20. Lock –

SCIENCE

- 1. What are vertebrate animals? _____.
- 2. Name 2 invertebrate animals _____, _____.
- 3. Copy and complete. Give examples of the following.

Mammals		
Reptiles		
Fish		
Amphibian		
Birds		

- 4. What is weathering?
_____.
- 5. Write 4 causes of weathering
 - a.
 - b.
 - c.
 - d.
- 6. Draw 3 pictures to show how plants can cause weathering.

--	--	--

7. What is food chain? _____.

8. Copy and complete.

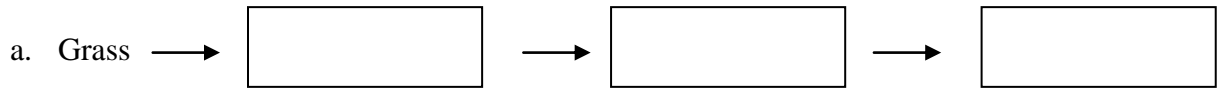

9. Which type of soil is good for plant growth. _____.

10. Label the layers of soil in the picture.

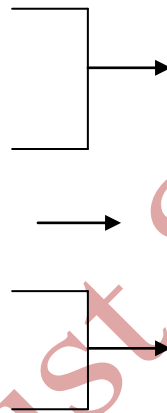
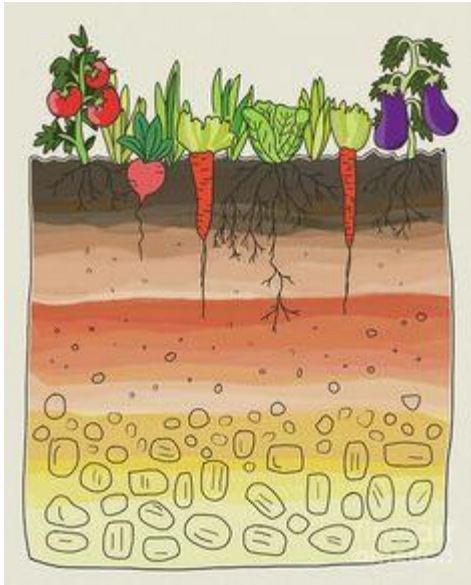

11. What is habitat? _____.

SOCIAL STUDIES

1. Name 4 types of transport.

- a. _____
- b. _____
- c. _____
- d. _____

2. Mention 2 road transport.

- a. _____
- b. _____

3. Write 2 disadvantages of ancient transport / communication.
 - a. _____
 - b. _____
4. What is the staple food for Zambian.
 - a. _____
 - b. _____
 - c. _____
5. Name the food we get from these animals:
 - a. Cow –
 - b. Chicken –
 - c. Pig –
 - d. Goat –
 - e. Pig –

6. Copy and complete

Name the food which belongs to these food groups.

Carbohydrates	Proteins	Vitamins

7. Vitamins are mainly _____ and _____.
8. Carbohydrates contain _____ and _____.
9. Copy and complete the table below.

Ceremony	Tribe
N'cwala	
Shimunenga	
Kuomboka	
Umutomboko	

10. What is fuel? _____.
11. Name two natural light.
 - a. _____
 - b. _____
12. Name 2 types of fuels we use in our homes.
 - a. _____
 - b. _____
13. Name 2 things you can find in the first aid box.
 - a. _____
 - b. _____

14. Name 2 musical instruments.

a. _____

b. _____

15. What do we call the first meal of the day? _____.

16. Name 2 food you can preserve using dry method.

a. _____

b. _____

17. Label the diagram below.

